

F/RTW/RTH

F/RTW/RTH

昌鑫機械工業股份有限公司
CHUNG SING MACHINERY CO., LTD.

429台灣 台中市神岡區豐工三路1號
NO.1, FENGGONG 3RD RD., SHENGANG DIST.,
TAICHUNG CITY 429, TAIWAN
TEL: 886-4-25252723 FAX: 886-4-25270957
E-mail: csmill@ms27.hinet.net <http://www.chungsing.com>

CNC 臥式 搪 銑 床
HORIZONTAL BORING & MILLING MACHINE

HB-800A 

HB-800A



刀庫 AUTOMATIC TOOL CHANGE SYSTEM

- 標準60刀庫，絕對式鏈條型刀庫，安全、穩定易操作，提升加工彈性及效率，適合各類型工件加工作業需求，雙向最短路徑選刀、減少非切削時間的浪費。
- Standard chain type with 60 tools magazine ATC, provide safety and stable tools exchange. This will enhances machining flexibility and efficiency.

工作台 WORKING TABLE

- NC伺服驅動高精度分度工作台，最小分割角度1度。
- 可承載3000kg的工作件及做精確角度分割。
- 搪孔、銑削、鉗孔、攻牙配合分度工作作業一次完成，可大幅節省工件安裝、調整、搬運及等待的時間。
- The high precision indexing work table driven by a servo motor provides high accurate indexing.
- The working table can be indexed at least 1 degree, available for maximum table loading up to 3000kg.
- The CNC boring and milling machine provides multiple faces machining at one time; boring, milling, drilling and tapping can be done just in one set-up.

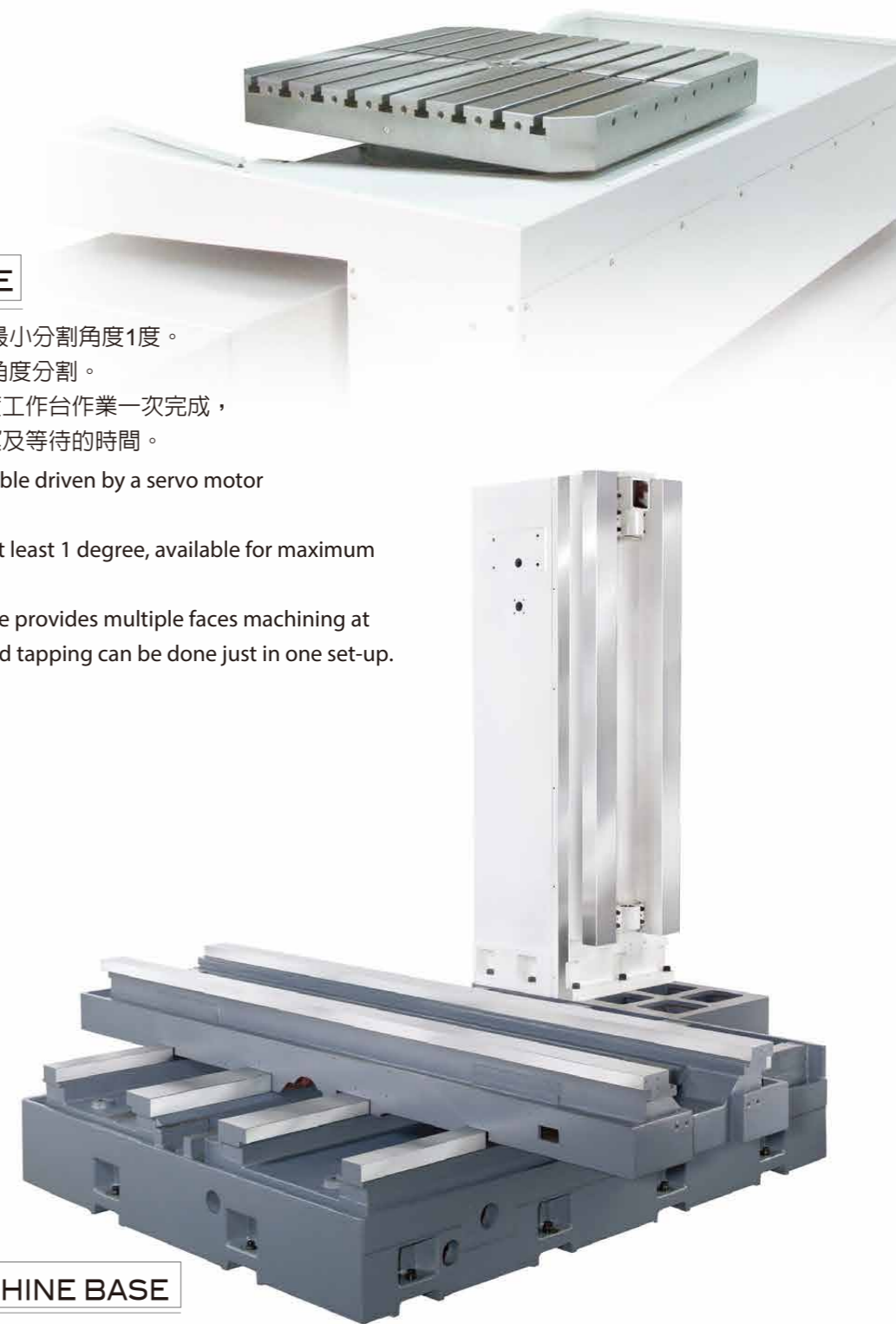

底座 MACHINE BASE

- 穩重，特寬一體成型的四滑軌底座。
- 在重切削時，絕對平穩，可獲得最佳動態水平。
- The extra heavy, wide one-piece base has 4 slideways.
- Box type column features outstanding stability in heavy duty machining and accurate dynamic level at all time.

CNC 臥式 搪 銑 床

CNC HORIZONTAL BORING & MILLING MACHINE



主軸 MAIN SPINDLE

- 主軸採套筒式設計配用NN系列高精密軸承，剛性佳，適合重切削。
- 全齒式，強力齒輪二段變速傳動，配合油冷式控制溫度及潤滑，避免熱變位問題，確保加工精度。
- The spindle is mounted on class SP high precision NN type double row roller bearing. Full geared drive spindle with two ranges of speed change provides flexible cutting capacity.
- The housing type designed spindle has circulating coolant with oil temperature control to eliminate thermal expansion on the spindle.

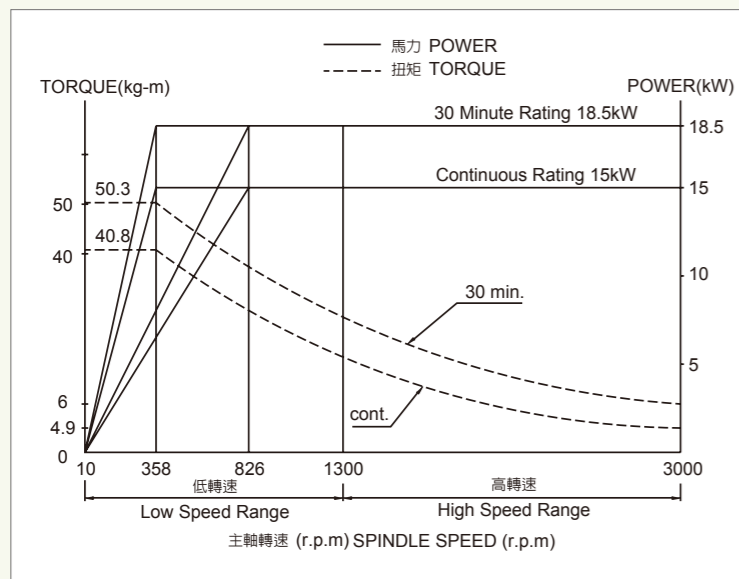

扭力圖 TORQUE CHART

- 主軸馬達15 / 18.5kW，二段變速。
- 最高轉速3000rpm，扭力輸出特佳。
- Powerful AC spindle motor: 15/18.5kW
- 2 steps variable speed at maximum 3000rpm.



控制器 CONTROL SYSTEM

- 懸吊式，可旋轉操控箱，配有可移式電子手輪，方便全方位操控。
- CNC控制器配用高性能及高信賴度Fanuc Oi-M控制器。
- The suspended control box can be rotated during operation and the portable MPG handwheel easily to set-up workpiece.
- With high reliable and high performance control FANUC Oi-M.

主軸油冷卻系統 SPINDLE OIL COOLER



選配 OPTIONAL

鍊板式排屑機 CHIP CONVEYOR WITH BUCKET

工作台防濺護罩 TABLE SPLASH GUARD

- 可拆卸式工作台防濺罩，可有效防止鐵屑及切削水飛濺，保持環境整潔(選配)。
- A removable splash guard helps to prevent chips and coolant splashing to keep the working area clean. (Optional)



CNC 臥式 搪銑床

CNC HORIZONTAL BORING & MILLING MACHINE

TABLE

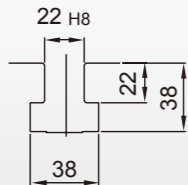
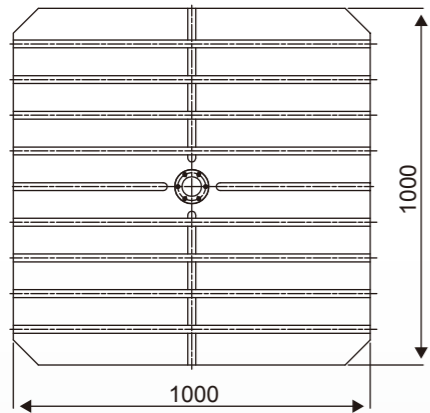

TOOL SHANK & PULL STUD BOLT

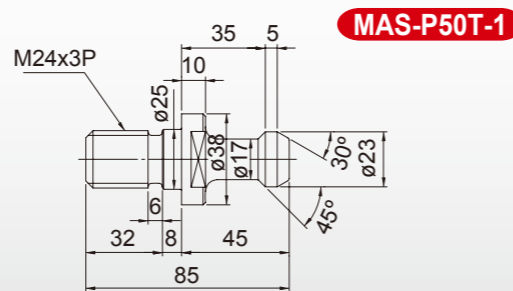
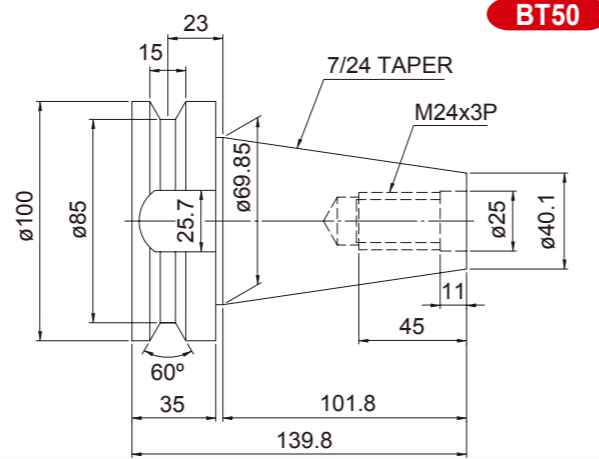

EXTERNAL DIMENSIONS

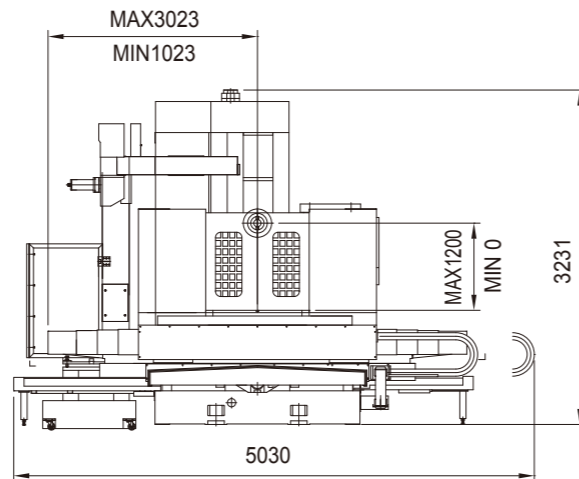
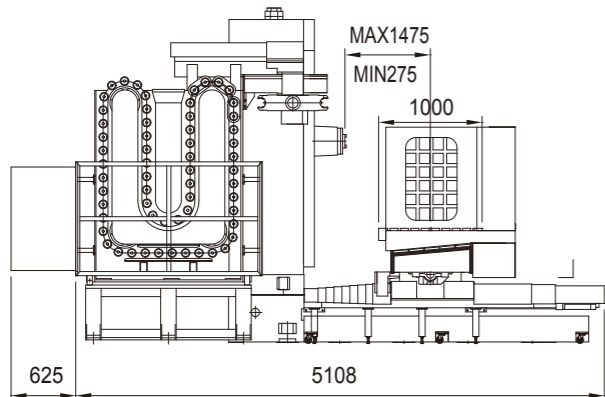
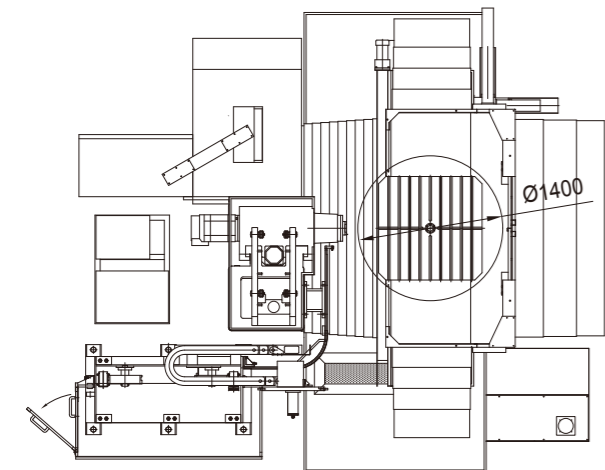

規格表 SPECIFICATIONS

HB-800A

型號 MODEL

1 工作台 TABLE

工作台尺寸	Table size	1000 x 1000	mm
T型槽	T slot (width x no. x pitch)	22H8 x 9 x 100	mm
最大負荷	Max. load capacity	3000	kg
分割角度	Min. indexing unit	1° (360分割)	deg
鎖緊力	Clamping force	5000	kg

2 行程 TRAVEL

X軸行程	X-axis travel	2000	mm
Y軸行程	Y-axis travel	1200	mm
Z軸行程	Z-axis travel	1200	mm
主軸鼻端至工作台中心距離	Spindle nose to table center	275 ~ 1475	mm
主軸中心至工作台面距離	Spindle center to table top	0 ~ 1200	mm

3 主軸 SPINDLE

錐孔	Spindle nose	BT50	
轉速/自動二段轉換	Speed / 2 range by S code	30 ~ 3000	rpm

4 進給 FEED

X.Y.Z軸快速移位速率	Rapid X, Y, Z-axis	15 / 12 / 15	m/min
工作台快速迴轉	Rapid Table Rotation	4	rpm
三軸切削進給速率	Feed rate of X, Y, Z-axis	1 ~ 6000	mm/min

5 自動換刀裝置 A.T.C.

刀庫容量	Magazine capacity	60	pcs
刀具規格	Pull stud	MAS-P50T-1	-
最大刀具長度	Max. tool length	400	mm
最大刀具重量	Max. tool weight	25	kg
最大刀具徑	Max. tool diameter	φ125 / φ250 (鄰空刀徑)	mm
刀具選擇方式	Tool selection	最短路徑選刀 Shortest path	-
換刀時間刀對刀(約)	Tool change time (approx.)	15	sec

6 馬達 MOTORS

主軸馬達	Spindle motor	15 / 18.5	kW
X/Y/Z/B軸馬達	Servo motor for X/Y/Z/B	7 / 7 / 7 / 4	kW
自動潤滑單元	Centralized lubrication pump	150	W
油壓單元	Hydraulic pump	2.2	kW
主軸油冷裝置	Spindle oil cooler pump	0.75	kW
切削液冷卻裝置	Coolant pump	1	kW

7 機械一般規格 GENERAL INFORMATION

氣壓需求	Pneumatic required	6	kg/cm²
切削液箱容量	Coolant tank	350	L
機械尺寸	Machine dimension	5030 x 5100 x 3250	mm
機械重量(約)	Machine weight (approx.)	18000	kg
CNC控制器	CNC control	Fanuc Oi-M	

標準附件 STANDARD ACCESSORIES

- 主軸油冷卻裝置
Spindle oil cooler
- 自動潤滑裝置
Centralized auto lubrication system
- 切削液冷卻裝置
Coolant system
- 切削吹氣
Air blow
- 電氣箱裝熱交換器
Heat exchanger for cabinet
- 石英工作燈
Work lamp
- 螺旋式切屑排送裝置
Screw type chip conveyor
- M30自動斷電裝置
M30 Automatic power off
- 可移動式電子手輪
Portable MPG handwheel
- 動作警示燈
Alarm lamp
- RS232界面接口
RS-232 interface port
- 工具箱及調整用工具
Tool box with adjustment tools
- 水平調整螺栓及墊塊
Leveling blocks and bolts

選配附件 OPTIONS ACCESSORIES

- 主軸中心出水 20Bar
Coolant thru spindle with pressure 20 bar
- 鍊板式排屑機
Chip conveyor with bucket
- 工作台防濺護罩
Table splash guard
- 變壓器
Transformer for other than 220V
- 直角工作台
Angle plate
- 油水分離機
Oil skimmer

本公司保留產品規格、外觀及配備等變更之權利。
Designs and specifications are subject to change without prior notice.